



BALAIS D'ESSUIE-GLACES

2026

Essuie-glaces LES DÉBUTS D'UNE SUCCESS STORY



1926,

Invention du premier
essuie-glace Bosch

AEROTWIN

2002

Invention du balai plat
AEROTWIN

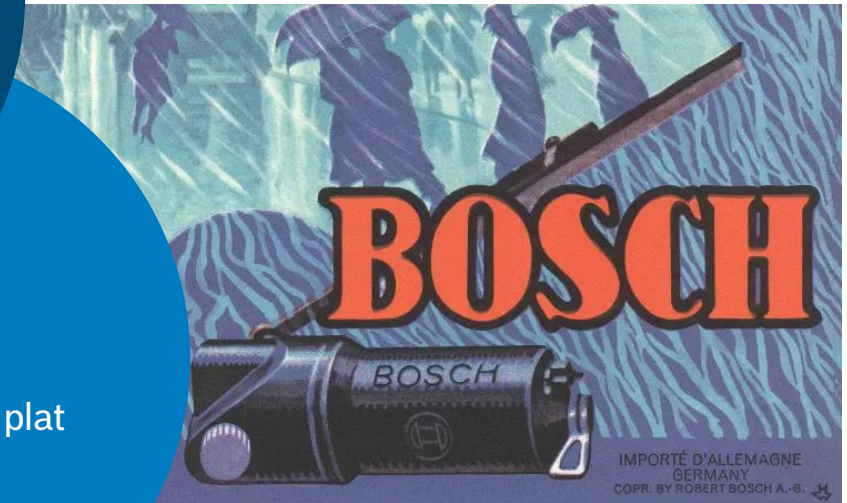

Aerotwin

Essuie-glaces

LES DIFFÉRENTS TYPES DE BALAIS

TWIN



- Balais conventionnels métalliques
- Turbulences à haute vitesse
- Usure irrégulière
- Gomme bi-matière

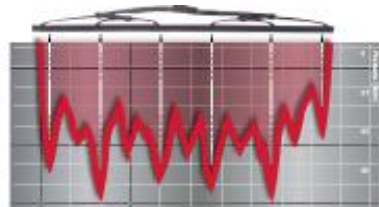

AEROTWIN



- Balais plats
- Excellent aérodynamisme
- Essuyage plus performant et régulier
- Gomme PPP



Essuie-glaces

100 ANS D'INNOVATIONS



Balai lave-phare

1972



Gomme bi-matière TWIN

1994



Gomme brevetée PPP

2012



Fixation brevetée AEROCLIP

2022

100

Years
Bosch
Wiper
Systems
1926-2026

2026

1926

1^{er} balai d'essuie-glace Bosch

1986

1^{er} balai TWIN Spoiler

1999

Invention du balai plat: Bosch Aerotwin

2013

JET Arm

2023

JET Blade



Essuie-glaces BOSCH J.E.T. BLADE

1st
To Market!

SUCCÈS EN PREMIÈRE MONTE

- Fixation : Bosch **AEROCLIP**
- Balai : Bosch **JET Blade**



Essuie-glaces

R&D

Matériaux avancés

- Augmentation de la part de matériaux recyclés
- Amélioration de l'efficacité des matériaux (plastique, acier et gomme)

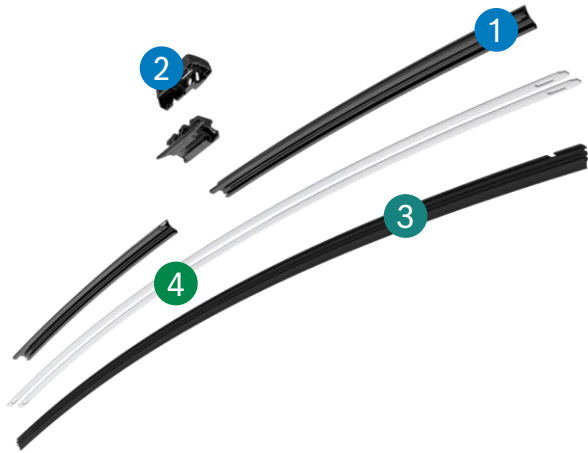

Technologie de revêtement

- Amélioration continue de notre gomme PPP
- Nouveaux challenges : réduction du bruit (EV)

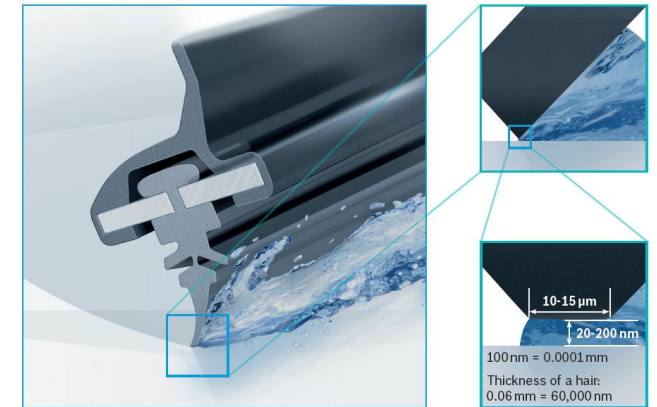
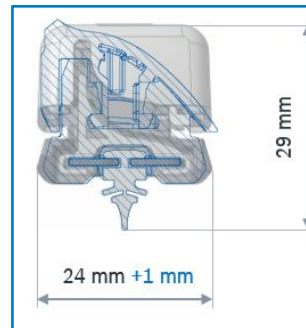

Essuie-glaces

PACKAGING PLUS DURABLE

AEROTWIN

**100%
RECYCLABLE**



**100%
CARTON**



CERTIFIÉ FSC*



*Emballage externe
des balais Aerotwin
certifié FSC.

NEW

Essuie-glaces

QUALITÉ, FIABILITÉ, SÉCURITÉ



Tests
acoustiques



Tests
d'endurance



Qualité de
la gomme

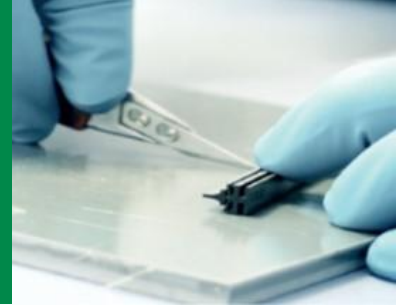

Tests à
haute
vitesse



Tests
climatiques



>30
tests
au total

Qualité d'essuyage

Résistance à la corrosion

Résistance aux UV

Résistance aux chocs

Essuie-glaces

GOMME POWER PROTECTION PLUS

Gomme
Brevetée!

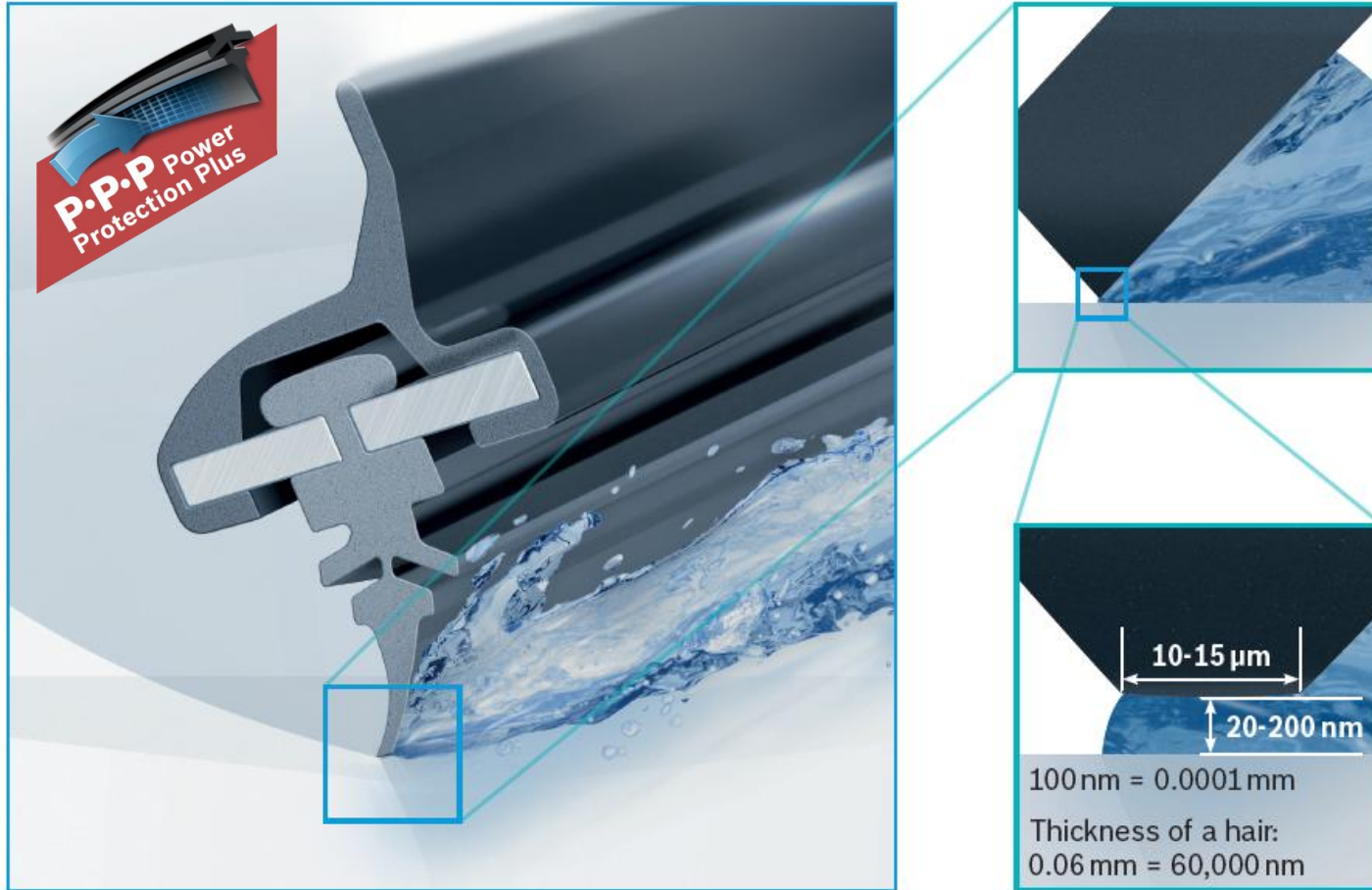

Plus EFFICACE

**Plus
SILENCIEUSE**

Plus DURABLE

Essuie-glaces

POURQUOI BOSCH ?



DURÉE DE VIE SUPÉRIEURE

Gomme brevetée
synthétique



CONFORT

Silencieux et performants
Faciles à installer



BEST BRAND 2025

Qualité éprouvée



100 ANS D'EXPERTISE

Leader de l'essuyage,
depuis toujours.



MADE IN EUROPE

Tous les balais AEROTWIN sont
fabriqués en Europe (Belgique
et Serbie)



24h
LE MANS®



BOSCH

PARTENAIRE PREMIUM

MERCI

