

BAC12 SERIES

BAC12-100R 12V AGM Battery



BOSCH
Invented for life

Applications

Electric tools
Vehicle in place of walking
Lawn mowers

Golf trolleys and golf carts
Portable apparatus, lights
and instruments

Electric toys
Illumination light
Fire alarms

Portable power
Wheelchairs
Medical equipment

Bosch Master Data

Short Order Part Number BAC12-100R	Bosch 13 Digit Part Number 0092L57156HD3	Nominal Voltage 12V	Nominal Capacity (20HR) 100.0 AH
Cold Cranking Amperes (CCA) 710.0 AH			
Case Size Dimension			
Length 305±3mm (12.10 inches)	Width 168±2mm (6.61 inches)	Container Height 207±3mm (8.15 inches)	Total Height (with Terminal) 213±3mm (8.39 inches)
Approx Weight 30.6 kg (67.5lbs)	Terminal T6	Container Material ABS	
Rated Capacity			
100.0 AH/5.00 A (20hr, 1.80V/cell, 25°C/77°F)	93.0 AH/9.33 A (10hr, 1.80V/cell, 25°C/77°F)	82.0 AH/16.4 A (5hr, 1.75V/cell, 25°C/77°F)	
74.1 AH/24.7 A (3hr, 1.75V/cell, 25°C/77°F)	60.3 AH/60.3 A (1hr, 1.60V/cell, 25°C/77°F)		
Max. Discharge Current 1200A (5s)	Internal Resistance Approx 4.9mΩ		

Operating Temp. Range

Discharge : -15-50°C (5-122°F)	Charge: 0-40°C (32-104°F)	Storage : -15-40°C (5-104°F)
Nominal Operating Temp. Range 25±3°C (77±5°F)	Cycle Use Initial Charging Current less than 30.0A. Voltage 14.4V-15.0V at 25°C (77°F) Temp. Coefficient -30mV/°C	
Standby Use No limit on Initial Charging Current Voltage 13.5V-13.8V at 25°C (77°F) Temp. Coefficient -20mV/°C		

Capacity affected by Temperature

40°C (104°F) 103%	25°C (77°F) 100%	0°C (32°F) 86%
-------------------	------------------	----------------

Self Discharge

Bosch BAC series batteries may be stored for up to 6 months at 25°C (77°F) and then a freshening charge is required. For higher temperatures the time interval will be shorter.

Certification Standards

AS/NZS
4029.2:2000



Constant Current Discharge (Amperes) at 25°C (77°F)

F.V/Time	10min	15min	20min	30min	45min	1hr	2hr	3hr	4hr	5hr	6hr	8hr	10hr	20hr
1.85V/cell	136.6	114.9	100.4	72.3	57.4	46.6	28.9	22.6	18.3	14.9	13.0	10.6	8.81	4.95
1.80V/cell	174.5	138.9	118.7	85.3	66.8	52.2	31.6	24.3	19.5	15.9	13.9	11.2	9.33	5.00
1.75V/cell	191.8	151.7	127.7	88.5	69.3	54.6	32.8	24.7	19.9	16.4	14.3	11.4	9.42	5.05
1.70V/cell	209.0	161.9	134.2	92.1	72.0	56.3	34.0	25.4	20.5	16.8	14.6	11.6	9.51	5.14
1.65V/cell	225.6	172.2	142.6	97.2	73.8	58.2	35.0	26.5	21.2	17.2	14.9	11.7	9.71	5.21
1.60V/cell	244.9	184.1	151.9	102.6	77.0	60.3	36.2	27.3	21.8	17.8	15.2	11.9	9.81	5.23

Constant Power Discharge (Watts) at 25°C (77°F)

F.V/Time	10min	15min	20min	30min	45min	1hr	2hr	3hr	4hr	5hr	6hr	8hr	10hr	20hr
1.85V/cell	254.8	216.7	191.4	138.9	111.0	90.4	56.4	44.1	35.8	29.2	25.6	20.9	17.4	9.91
1.80V/cell	321.3	257.9	222.8	161.9	128.1	100.7	61.2	47.2	38.0	31.2	27.3	22.2	18.5	10.0
1.75V/cell	348.7	279.0	237.7	167.2	132.3	104.9	63.3	47.9	38.8	32.0	28.0	22.5	18.6	10.1
1.70V/cell	374.7	295.7	248.4	173.4	137.2	108.0	65.6	49.2	39.7	32.7	28.6	22.8	18.8	10.3
1.65V/cell	401.5	312.3	262.6	182.1	140.1	111.2	67.2	51.1	41.0	33.6	29.2	23.1	19.2	10.4
1.60V/cell	428.5	330.0	276.9	190.3	144.7	114.2	69.1	52.4	42.1	34.5	29.7	23.3	19.4	10.4

Product Dimension & Design

T6 Terminal
Unit: mm [inches]

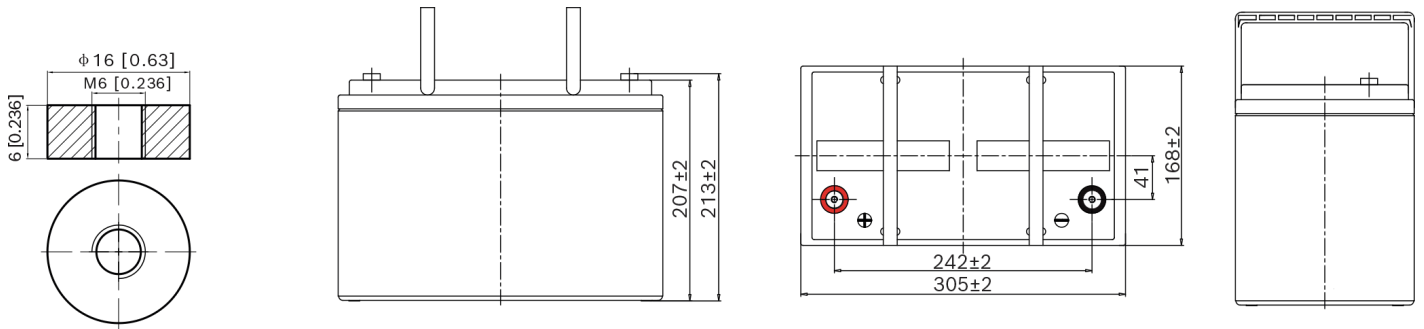

Product Performance Overview

Discharge Characteristics

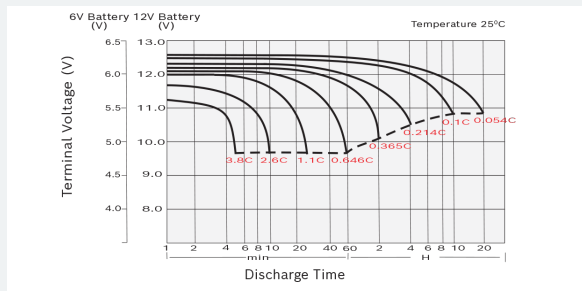

Charging Characteristics

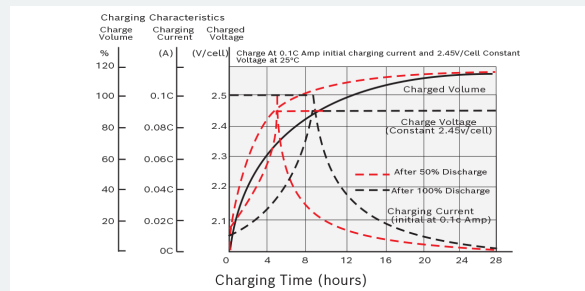

Temperature Effects in Relation to Battery Capacity

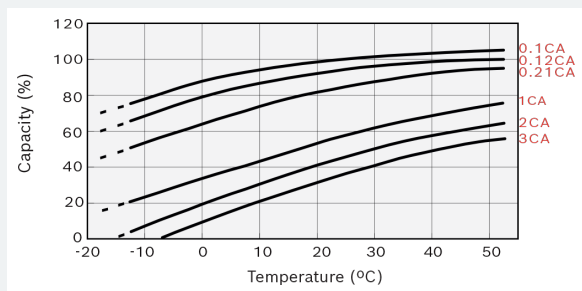

Cycle Life in Relation to Depth of Discharge

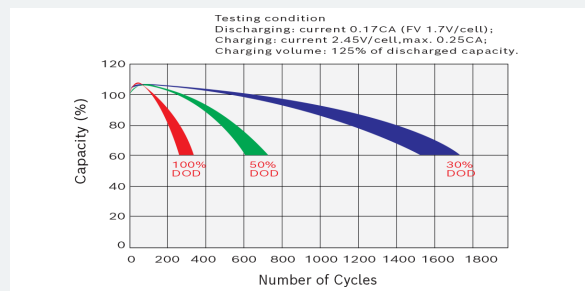

Self Discharge Characteristics

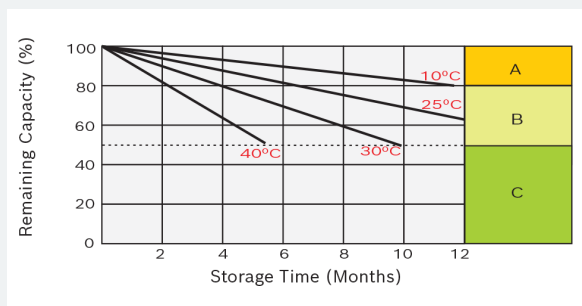

- A** No supplementary charge required (Carry out supplementary charge before use if 100% capacity is required.)
- B** Supplementary charge required before use. Optional charging way as below:
 - Charged for above 3 days at limited current 0.25CA and constant volatge 2.25V/cell.
 - Charged for above 20 hours at limited current 0.25CA and constant volatge 2.45V/cell.
 - Charged for 8~10 hours at limited current 0.05CA.
- C** Supplementary charge may often fail to recover the capacity. The battery should never be left standing till this is reached.

Your address for genuine Bosch quality:

Dealer stamp here: