



**BOSCH**

Invented for life

# Bosch M6 Mega Power Ride

RBTZ10S-N - Maintenance Free / Absorbent Glass Mat Technology

## Applications

For Starting, Lighting, Ignition (SLI) applications in Motorcycles, Scooters, ATVs, Small Watercraft



Image is generic & may vary to actual product

## Bosch Master Data

Short Order Part Number

RBTZ10S-N

Product Series

M6 Mega Power Ride

Bosch 10 Digit Part Number

0092M67001

Technology

Absorbent Glass Mat

EAN Barcode

4047026704853

Warranty Period

Refer [www.boschaftermarket.com.au](http://www.boschaftermarket.com.au)

Refer [www.boschaftermarket.co.nz](http://www.boschaftermarket.co.nz)

## Technical Information

Nominal Voltage

12V

Nominal Capacity (C10)

8.6AH

Cold Cranking Amperes (CCA)

190 Amps

### Case Size Dimension

Length

150 mm (5.90 inches)

Width

88 mm (3.46 inches)

Total Height (with Terminal)

93 mm (3.66 inches)

Approx Weight (Gross)

3.15 kg (6.93 lbs)

Terminal

(+)

Container Material

Polypropylene

Lid Design

Labrynth Lid

# Product Dimension & Design

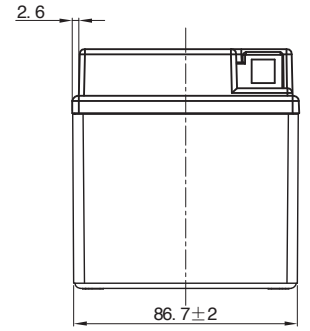
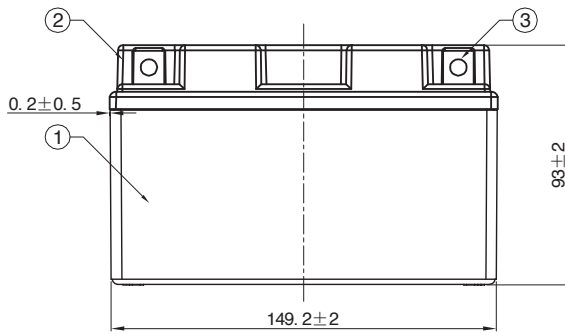
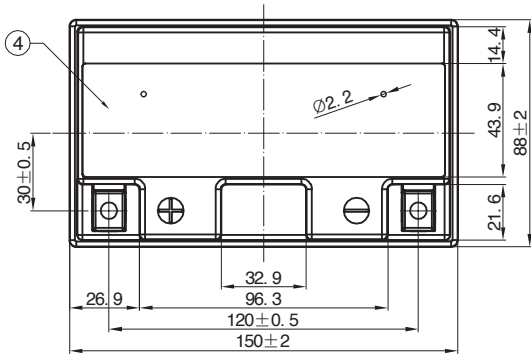
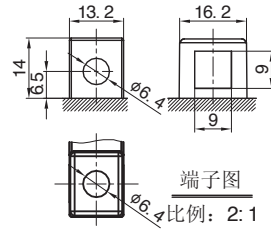

Your address for genuine Bosch quality:

**Dealer stamp here:**