

**BOSCH**

Invented for life

Bosch SM Mega Power Plus

57013 - Maintenance Free / Calcium, Calcium Technology

Applications

Passenger Vehicle
Light Commercial Vehicle

Bosch Master Data

Short Order Part Number

57013

Product Series

SM Mega Power Plus

Bosch 10 Digit Part Number

0092S37480

Technology

Calcium, Calcium

EAN Barcode

4047025475440

Warranty Period

Refer www.boschaftermarket.com.auRefer www.boschaftermarket.co.nz

Technical Information

Nominal Voltage

12V

Cold Cranking Amperes (CCA)

770 Amps

Nominal Capacity (20HR)

70AH

Reserve Capacity

110 Mins

Case Size Dimension

Length

278 mm (10.94 inches)

Total Height (with Terminal)

190 mm (7.48 inches)

Width

175 mm (6.89 inches)

Case Size

LN3

Container Height

168 mm (6.61 inches)

Approx Weight (Gross)

19.48 kg (42.85 lbs)

Lid Design

Labrynth Lid

Terminal

(+)

Base Hold Down

B3

Container Material

Polypropylene

Product Dimension & Design

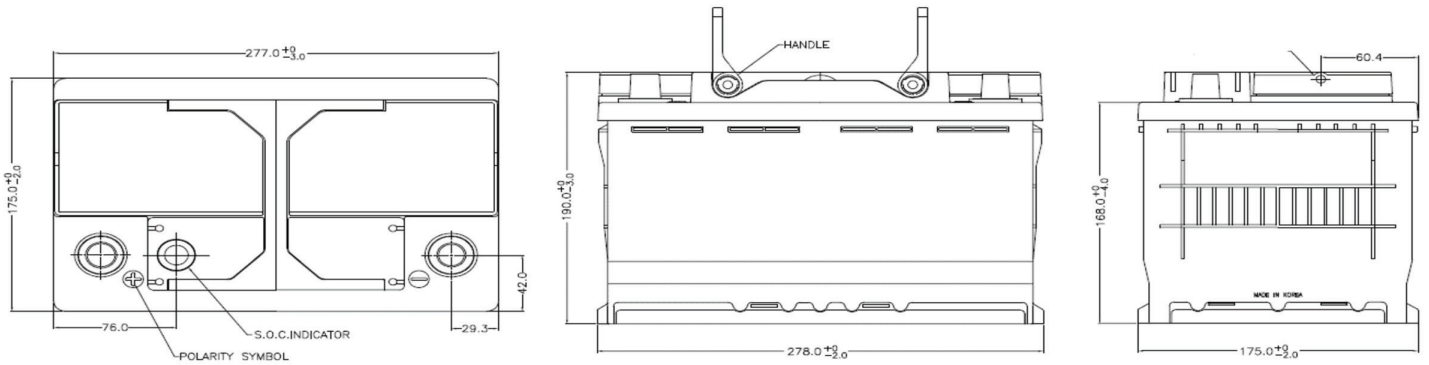

Product Performance Overview

Depth of Discharge Cycling Test

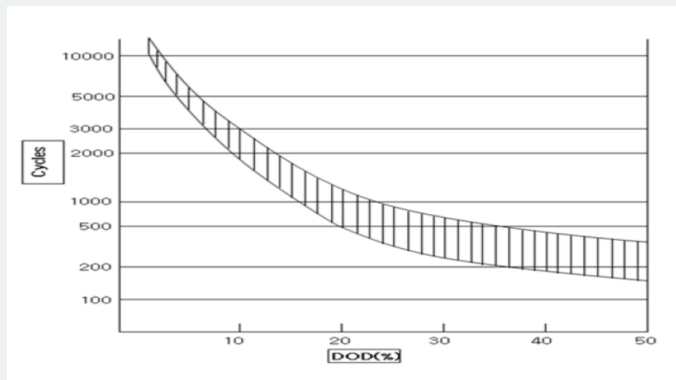

Discharge Characteristics Test

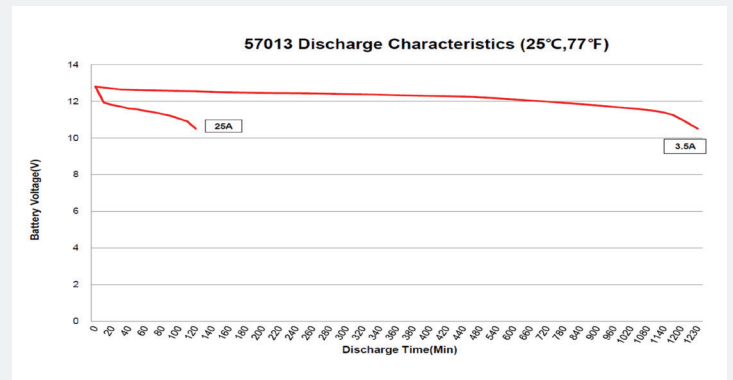

Your address for genuine Bosch quality:

Dealer stamp here: