

**BOSCH**

Invented for life

Bosch Mega Power Plus

65-7MF - Maintenance Free / Calcium, Calcium Technology

Applications

Passenger & Light Commercial Vehicles

Bosch Master Data

Short Order Part Number	Bosch 13 Digit Part Number	EAN Barcode
65-7MF	0092S47045HH0	4047025475754
Product Series	Technology	Warranty Period
Mega Power Plus	Calcium, Calcium	Refer www.boschaftermarket.com.au
		Refer www.boschaftermarket.co.nz

Technical Information

Nominal Voltage	Nominal Capacity (20HR)	Reserve Capacity
12V	85 AH	160 Mins

Cold Cranking Amperes (CCA)

850 Amps

Case Size Dimension

Length	Width	Container Height
302 mm (11.88 inches)	189 mm (7.44 inches)	171 mm (6.73 inches)

Total Height (with Terminal)

191 mm (7.51 inches)

Approx Weight (Gross)	Terminal	Container Material
21.4 kg (47.0 lbs)	(+)	Polypropylene
Lid Design	Base Hold Down	
Labrynth Lid	B8	

Product Dimension & Design

Terminal

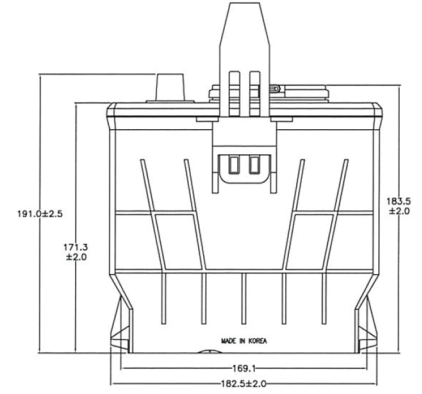
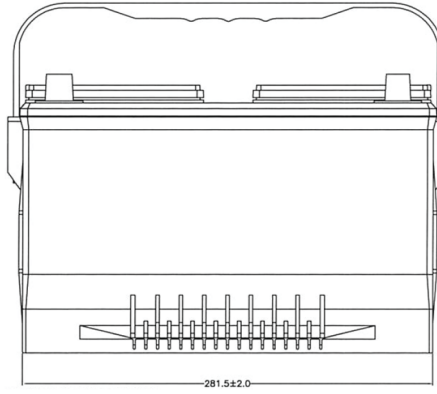
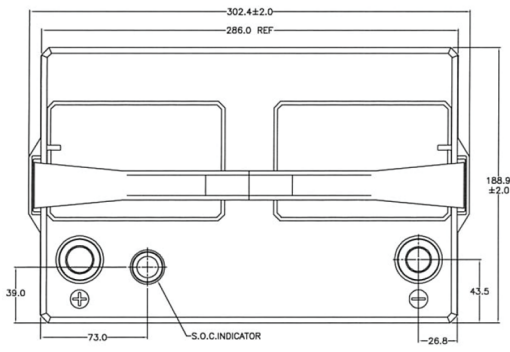
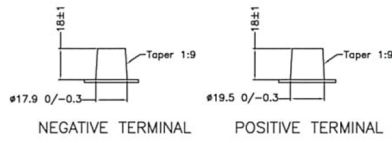

Product Performance Overview

Depth of Discharge Cycling Test

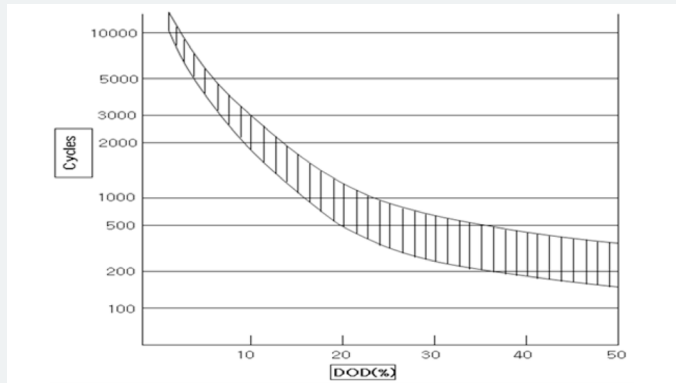

Discharge Characteristics Test

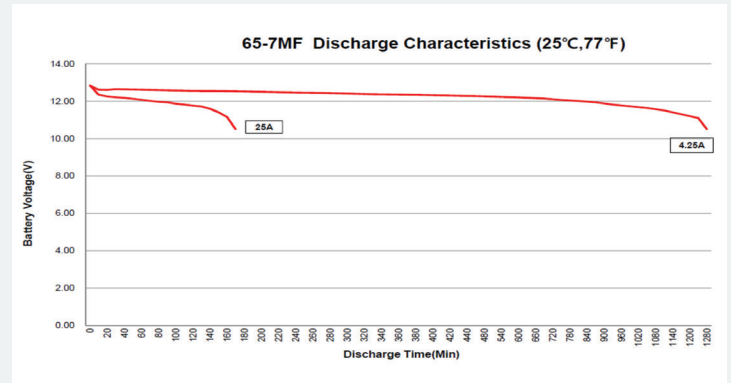

Your address for genuine Bosch quality:

Dealer stamp here: