

**BOSCH**

Invented for life

Bosch SM Mega Power Plus

U1-260 - Maintenance Free / Calcium, Calcium Technology

Applications

Passenger Vehicle
Light Commercial Vehicle

Bosch Master Data

Short Order Part Number

U1-260

Product Series

SM Mega Power Plus

Bosch 10 Digit Part Number

0092S47077

Technology

Calcium, Calcium

EAN Barcode

4047025570794

Warranty Period

Refer www.boschaftermarket.com.auRefer www.boschaftermarket.co.nz

Technical Information

Nominal Voltage

12V

Cold Cranking Amperes (CCA)

260 Amps

Nominal Capacity (20HR)

26AH

Reserve Capacity

33 Mins

Case Size Dimension

Length

196 mm (7.71 inches)

Total Height (with Terminal)

184 mm (7.24 inches)

Width

128 mm (5.03 inches)

Case Size

U1

Container Height

162 mm (6.37 inches)

Approx Weight (Gross)

7.76 kg (17.00 lbs)

Lid Design

Labrynth Lid

Terminal

(+)

Base Hold Down

B0

Container Material

Polypropylene

Product Dimension & Design

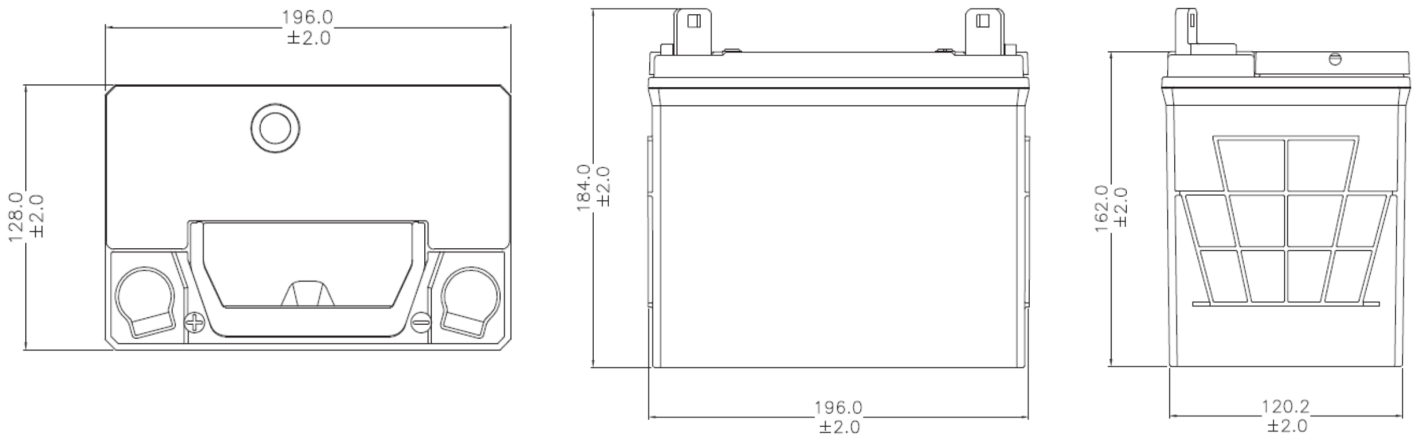

Product Performance Overview

Depth of Discharge Cycling Test

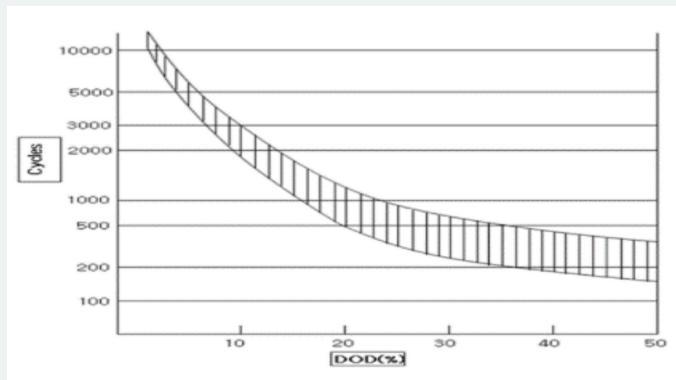

Discharge Characteristics Test

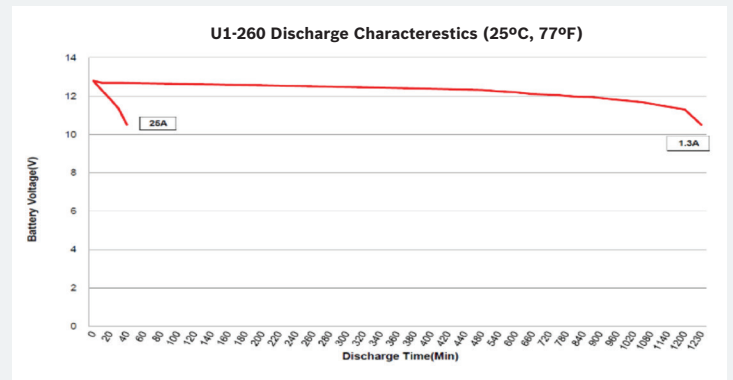

Your address for genuine Bosch quality:

Dealer stamp here: