



BOSCH

Invented for life

Bosch SM Mega Power Silver

90D23L - Maintenance Free / Calcium, Silver Technology

Applications

Passenger Vehicle
Light Commercial Vehicle



Image is generic & may vary to actual product

Bosch Master Data

Short Order Part Number

90D23L

Product Series

SM Mega Power Silver

Bosch 10 Digit Part Number

00986A02234

Technology

Calcium, Silver

EAN Barcode

4047025475938

Warranty Period

Refer www.boschaftermarket.com.au

Refer www.boschaftermarket.co.nz

Technical Information

Nominal Voltage

12V

Nominal Capacity (20HR)

75AH

Reserve Capacity

125 Mins

Cold Cranking Amperes (CCA)

650 Amps

Case Size Dimension

Length

230 mm (9.05 inches)

Width

172 mm (6.77 inches)

Container Height

200 mm (7.87 inches)

Total Height (with Terminal)

222 mm (8.74 inches)

Case Size

D23

Approx Weight (Gross)

16.60 kg (36.52 lbs)

Terminal

(-+)

Container Material

Polypropylene

Lid Design

Labrynth Lid

Base Hold Down

B7

Product Dimension & Design

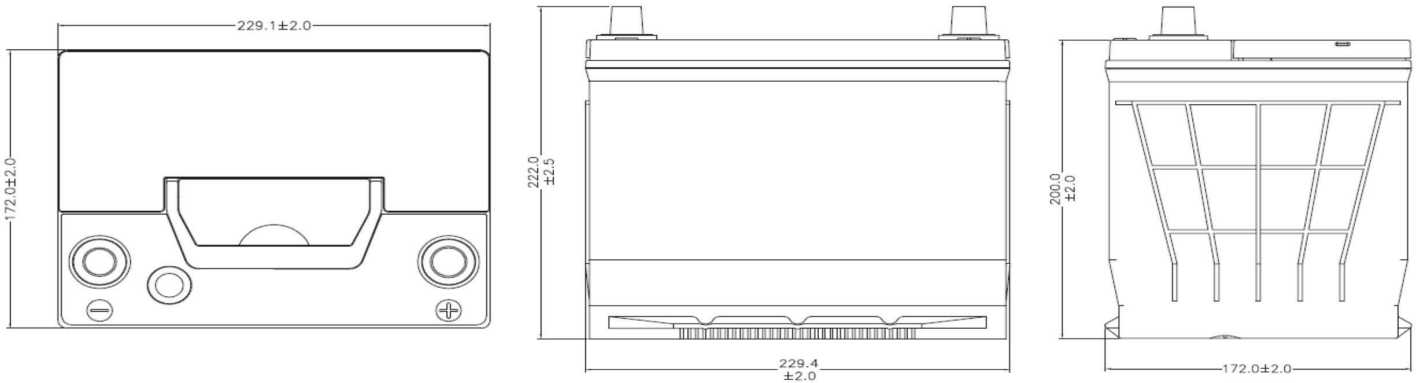

Product Performance Overview

Depth of Discharge Cycling Test

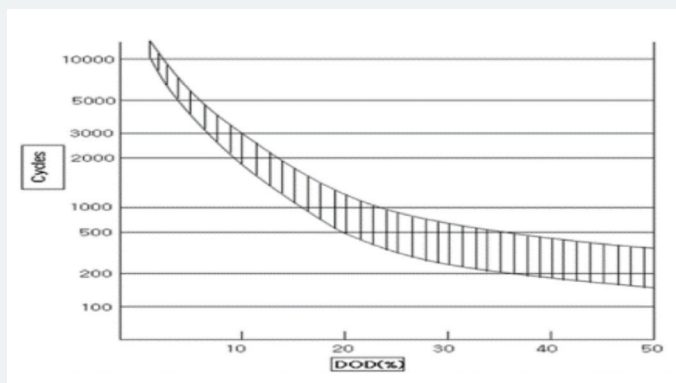

Discharge Characteristics Test

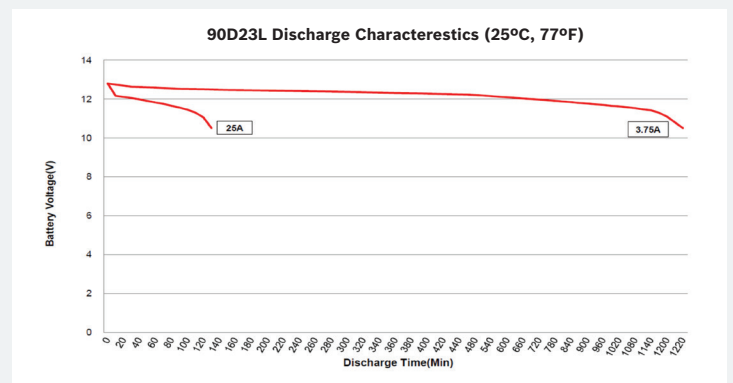

Your address for genuine Bosch quality:

Dealer stamp here: