

**BOSCH**

Invented for life

Bosch SMT Mega Power Plus

31-900T – 12V Calcium-Calcium Technology

Applications

Light & Heavy Commercial Applications including Industrial

Bosch Master Data

| | | |
|--------------------------|----------------------------|------------------------------------------------------------------------------------------------------------------------------------------------------------------------|
| Short Order Part Number | Bosch 13 Digit Part Number | EAN Barcode |
| 31-900T | 0092S37157HH0 | 4047024824133 |
| Product Series | Technology | Warranty Period |
| SMT Mega Power Plus (T4) | Calcium, Calcium | Refer www.boschaftermarket.com.au Refer www.boschaftermarket.co.nz |

Technical Information

| | |
|-----------------|-------------------------|
| Nominal Voltage | Nominal Capacity (20HR) |
| 12V | 100 AH |

Case Size Dimension

| | | |
|------------------------------|---------------------|---------------------|
| Length | Width | Container Height |
| 330mm (13 inches) | 173mm (6.81 inches) | 218mm (8.58 inches) |
| Total Height (with Terminal) | | |
| 239mm (9.40 inches) | | |

| | | |
|-----------------------------------------------------------|-------------------------------|-----------------------------|
| Approx Weight (Gross) | Terminal | Grid |
| 10.48 kg (23 lbs) | G (Threaded) | Expanded |
| Container Material | Lid Design | |
| Polypropylene | Labrynth Lid | |
| Rated Capacity | | Internal Battery Resistance |
| Mins @ 25A = 160 (20hr, 1.75V/cell, 26.7°C/80°F) = 100 AH | | 2.9mΩ |
| Operating Temp. Range | Nominal Operating Temp. Range | Self Discharge |
| Discharge: -30~60°C (-22~140°F) | 25°C/77°F | Refer chart |

Product Dimension & Design

G (Threaded)

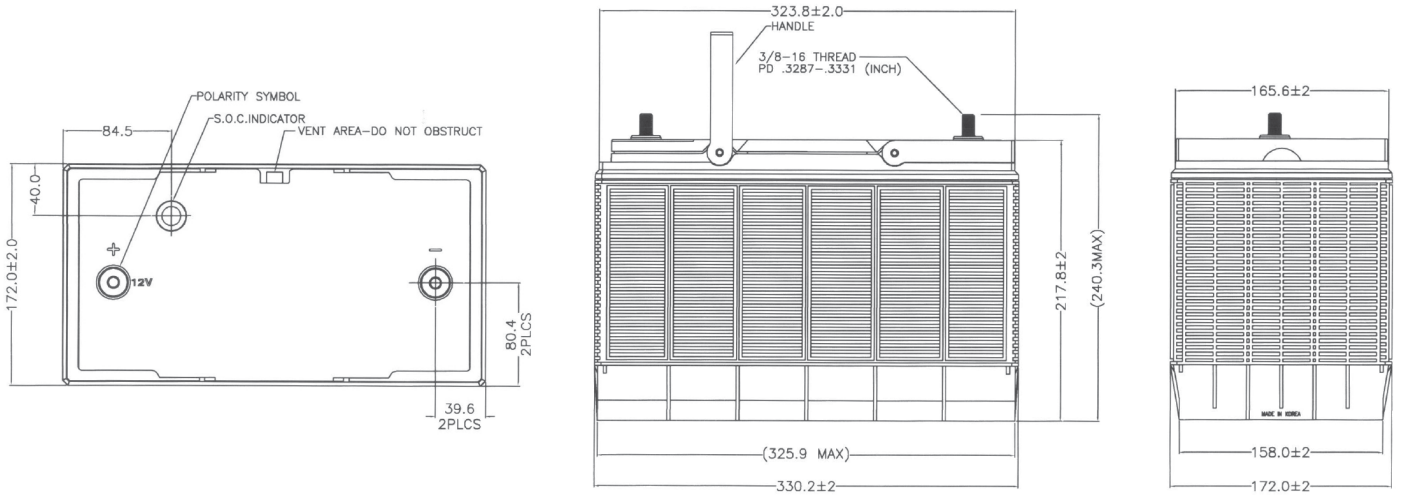

Product Performance Overview

Depth of Discharge Cycling Test

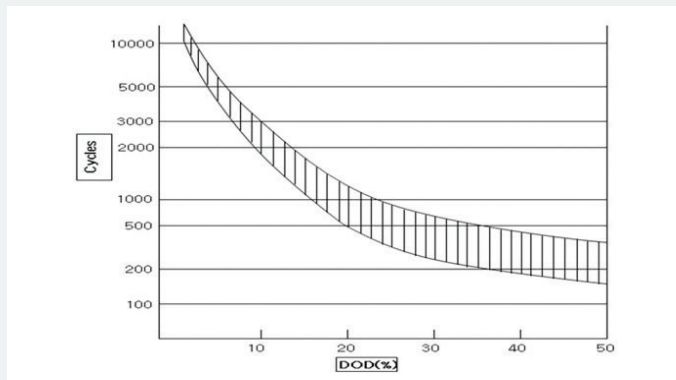

Discharge Characteristics Test

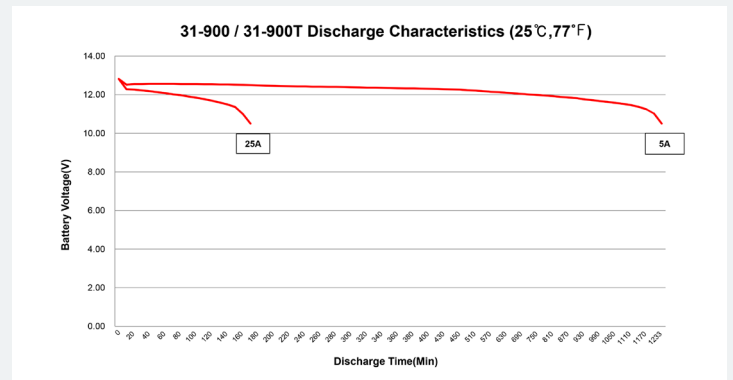

Your address for genuine Bosch quality:

Dealer stamp here: