

Electric steering systems

High-quality spare parts for passenger cars and light commercial vehicles

Basis for driver assistance systems and automated driving functions in modern vehicles

In rack-and-pinion-based electric power steering systems, steering assistance is provided by an electric motor whose power is transmitted to the rack via a servo gearbox. As the electric motor is supplied with power via the vehicle electrical system, electric steering systems are suitable for all drive types. In conjunction with sensors, servo gear and control unit, they form an important basis for driver assistance systems and automated driving functions. Thus, they enable efficient and precise steering.

Reliability for a safe journey

As a particularly safety-relevant vehicle component, steering systems are mostly maintenance-free and their durability is designed for the entire vehicle life cycle. However, if they need to be replaced – for example due to an accident or mechanical overload – Bosch offers workshops high-quality spare parts for passenger cars and light commercial vehicles.

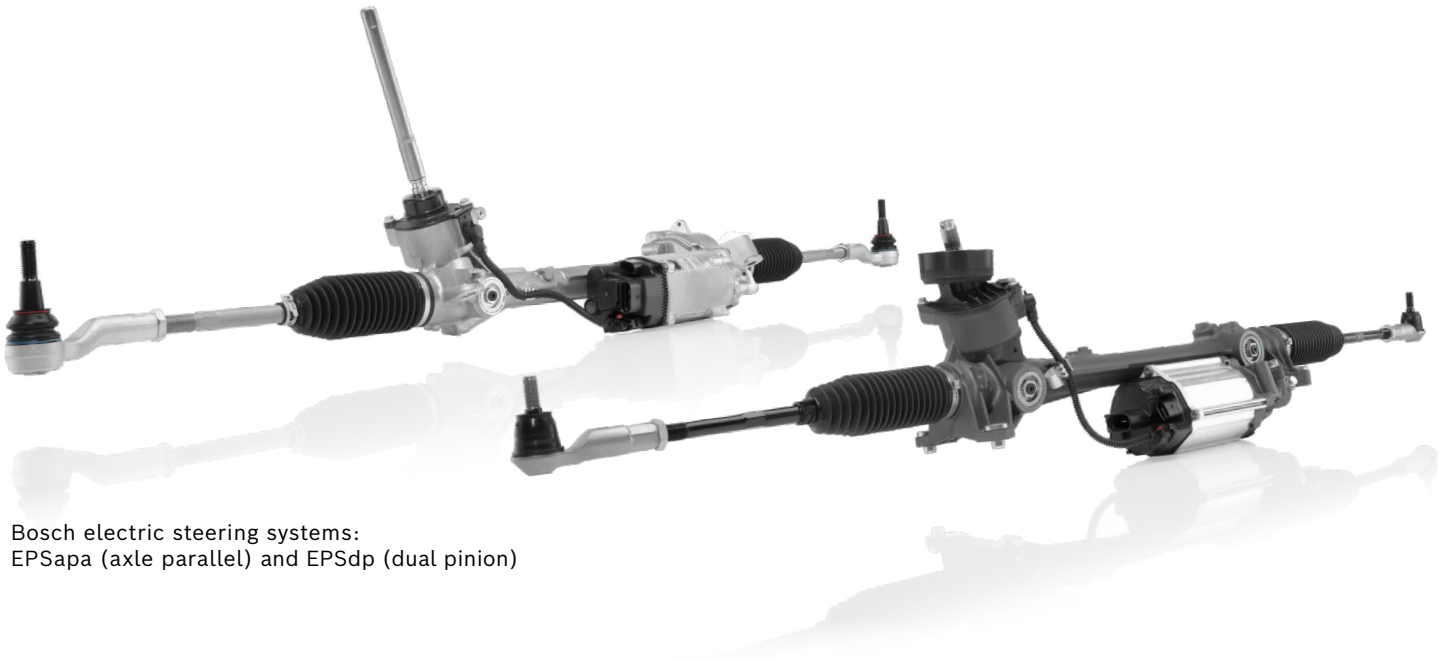

Bosch electric steering systems:
EPSapa (axle parallel) and EPSdp (dual pinion)

Advantages at a glance



Comprehensive original equipment experience:
for steering systems that meet the latest technological standards



High-quality materials: for a long service life



Stringent functional and quality tests according to OE standards:
for safe and reliable operations



Fast availability: for short downtimes



Comprehensive service documents and manuals included:
for professional removal, installation and putting into operation

Invented for life



The spare parts program

Bosch offers electric steering systems for the following vehicle manufacturers:

Manufacturer	VIO coverage*
BMW	6,561,657
FIAT/Alfa Romeo	217,985
Jaguar/Land Rover	2,594,173
Mercedes-Benz	4,362,339
Volkswagen Group	12,833,505

*As of 10/2024



Electric steering systems and steering attachment parts by Bosch are precisely matched

The range of electric steering systems is defined by:



Coverage of over 26 million vehicles in operation



Compatibility for vehicles with combustion, hybrid or electric drives



Availability of selected steering systems also as Bosch exchange parts



Did you know?

Bosch offers steering systems and attachment parts from a single source.



Find out more about the four practical Bosch attachment parts kits!



Workshop tip

Replacing electric steering systems: easy and efficient with Remote Diagnostics Service

With the Remote Diagnostics Service, qualified Bosch experts access the vehicle online and support the electrical commissioning.



Register now and try it out!

