



BOSCH

Invented for life

Ignition components

Bosch high-quality spare parts
for reliable ignition-system repairs





Did you know?

Actually, spark plugs were just a spin-off product of the development of the high-voltage magneto ignition system.

300 million

spark plugs are currently produced by Bosch every year.

Ignition systems by Bosch

High fuel economy, low emissions and top fun to drive – that's the features demanded of modern vehicles. A lot of them are equipped with new and innovative solutions based on Bosch system know-how. Among them, the ignition system plays a key role.



Ignition components, diagnoses and services.

The workshop and retail range includes high-quality spare parts, modern workshop equipment and ESI[tronic] 2.0 software for diagnoses, servicing and repairs as well as special trainings.



Global presence

More than 17 000 associates in 150 countries and an extensive dealer network reliably ensure target-oriented workshop support and local availability of spare parts.



Innovative strength

In 1887, it all started with the low-voltage magneto ignition system for stationary engines produced by Bosch. Constant innovations ensured ongoing progress. Today, ignition systems are integrated into modern engine management systems.



System competence and know-how

Thanks to its system development experience, Bosch knows the technical requirements placed on motor vehicles very well. The aftermarket therefore also benefits from modern products featuring high reliability.

Innovations by the inventor

As early as 1897, Bosch installed a magneto ignition system he built for stationary engines into a motor trike. Two years later, the series production of low-voltage magneto ignition systems for car engines was started. With the aid of ignition systems, Bosch became an international automotive supplier.

High voltage and spark plugs

In 1902, Bosch presented the high-voltage magneto ignition also known as arc ignition. It forwarded the voltage it generated to the spark plugs using cables or leads. The spark plug itself was actually just a spin-off product allowing Bosch to produce and supply the whole system. And yet it became one of the best-selling Bosch products. Down to the present day, people remember the great race victories. For more than half a century, racing legends such as Camille Jenatzy, Juan Manuel Fangio and Rudolf Caracciola proved the great performance of Bosch spark plugs. Today, Bosch produces more than 300 million spark plugs annually and continues being a technology partner in racing.

Ignition coils, modules, leads and spark plugs for modern Bosch ignition systems

Today Bosch supplies its partners with the complete range of ignition components.



The high-voltage magneto ignition system with spark plugs was universally applicable and a sudden and huge success for Bosch.



Modern Bosch ignition components

Ignition coils

Overview

Highly efficient: Ignition coils are part of the engine management of gasoline engines. They provide the energy needed for the ignition spark at the spark-plug electrodes. For this purpose, the battery voltage (e.g. 12 volts) is transformed into a high voltage from 15 000 to more than 30 000 volts.



Compact ignition coils
and pencil ignition coils

Each spark plug is connected to a single-spark ignition coil. In this way, each cylinder has its own independent source of power.

There are two types of single-spark ignition coils: pencil and compact ignition coils.

With pencil ignition coils, the high-voltage transformer is located in the cylindrical coil body – in compact ignition coils, it is in the coil head.

Single-spark ignition coils are installed directly onto the spark plug – without ignition leads. This maximizes the transfer of energy to the spark plug. Avoiding high-voltage cables (ignition leads) reduces the potential for engine misfire.

Multi-spark ignition coils provide the required ignition voltage for several spark plugs. The high voltage is distributed by ignition leads. Multi-spark ignition coils are particularly robust and resilient.

Advantages at a glance:

- ▶ **The comprehensive and complete range** includes the right ignition coil for each application – even for older vehicles.
- ▶ **Bosch ignition coils feature high performance** paired with high functionality and top cold-start performance. Their high heat and vibration resistance makes them particularly reliable.
- ▶ **The corrosion-resistant connector technology is a result of Bosch inhouse development of ignition components.** Combined with top manufacturing quality, it ensures high reliability and a long service life.





Multi-spark ignition coil

Ignition coils

Product details

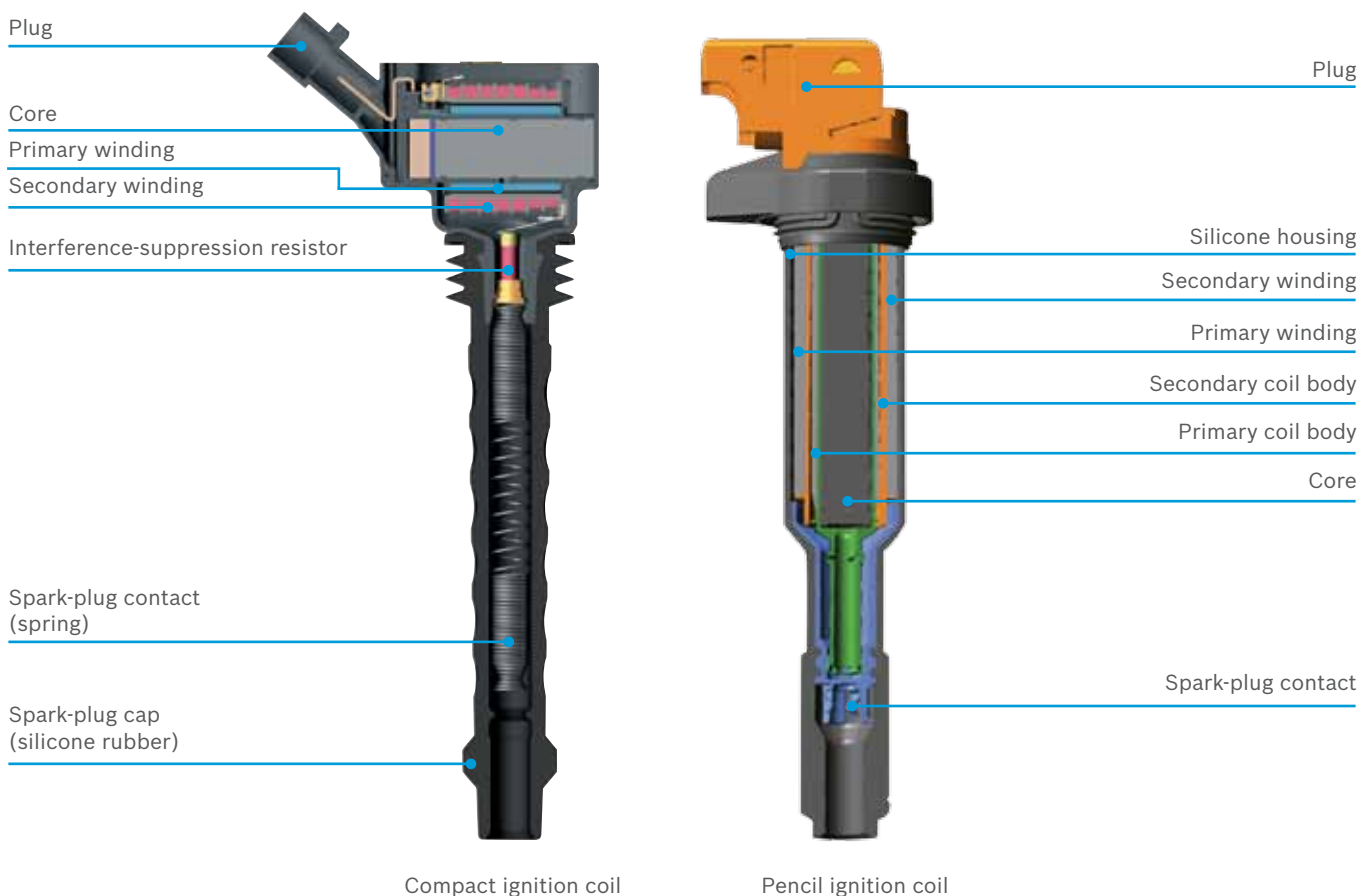
Two circuits, a magnetic field and a spark: Opening the primary circuit of the ignition coil, a high-voltage pulse is generated at the secondary circuit. The high voltage thus generated is then transmitted to the spark plug.





i Asphalt ignition coil – reliable operation

This conventional single-spark ignition coil is contact-controlled. That is, the current flowing through the coil is switched on and off by a contact within the ignition distributor. The high voltage is mechanically distributed to the spark plugs by means of a rotor inside the ignition distributor.

- ▶ For improved environmental compatibility, the oil filling formerly used was substituted by asphalt.
- ▶ This material also improves these ignition coils' insulation.

Ignition leads

Overview

Transmission reliability with Bosch quality: Transmitting the high voltage from the ignition distributor to the spark plugs without any losses, Bosch ignition leads fulfill their task in a highly reliable manner.



The product range comprises of two main product lines. Their specifications are perfectly coordinated with the manufacturers' requirements. As a result, they feature a high market coverage.

Silicone Power high-performance ignition leads feature inner conductors made of fiberglass. They are specifically designed for vehicles with resistance ignition leads as original equipment.

Silicon Copper high-performance ignition leads come with inner conductors made of copper. They are used for all vehicles equipped with copper-core ignition leads as original equipment.

Advantages at a glance:

- ▶ **Inner conductors made of carbon-impregnated fiberglass** make Silicone Power ignition leads particularly break-proof and durable.
- ▶ **Thanks to their tin coating**, inner conductors made of copper are particularly conductive.
- ▶ **Bosch ignition leads are very robust** and resistant to heat, cold and fluids.
- ▶ **The connectors are corrosion-resistant** thus ensuring safe contacting.
- ▶ **The exterior insulation is made of silicone only** – without any PVC. This supports the radio interference suppression and a long service life.

Ignition leads

Product details

Design-related: The high resistance to heat, cold and both mechanical and chemical influences increase the safety of the connection with the engine and the catalytic converter.

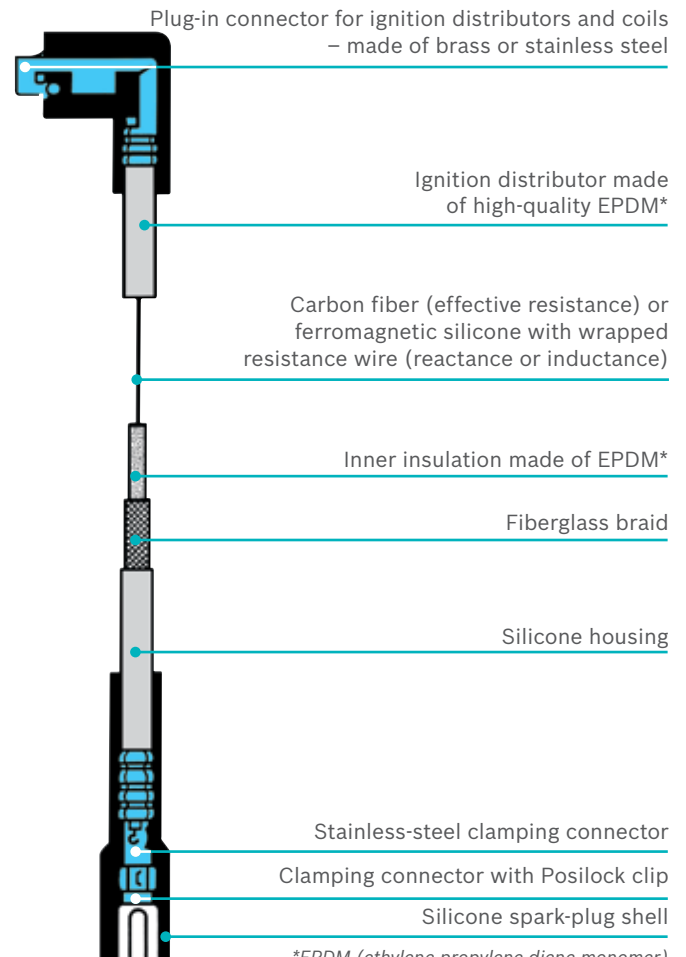
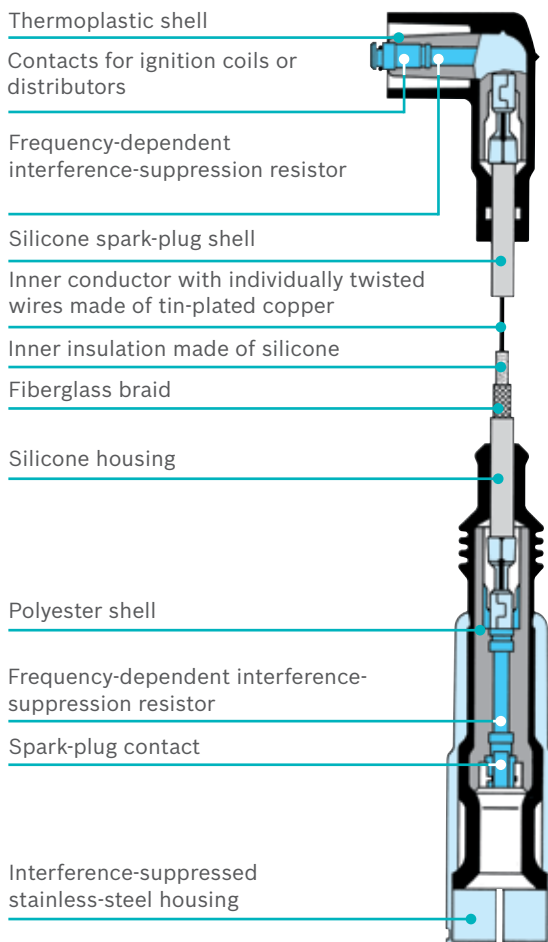

*EPDM (ethylene propylene diene monomer) is a highly resilient artificial rubber.

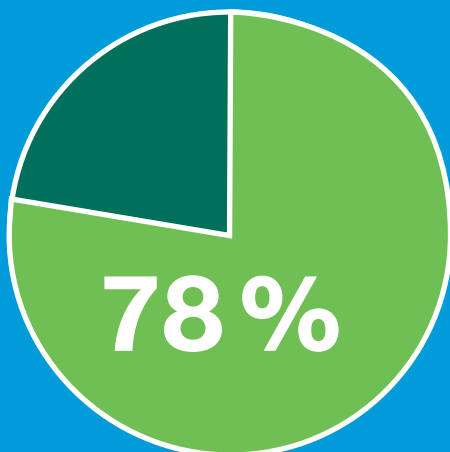

i 78% market coverage

Thanks to the particularly high coverage of the Bosch range of ignition leads, there is a Silicone Power or Silicone Copper ignition lead available for almost any vehicle model.

- ▶ More than 220 sets of resistor ignition leads.
- ▶ More than 410 pre-assembled individual resistance ignition leads
- ▶ Some 130 pre-assembled individual copper-core ignition leads
- ▶ More than 110 sets of copper-core ignition leads

Spare parts for ignition distributors

Overview

Complete range: Bosch is a leading supplier worldwide providing its partners with a complete range of all ignition components – including wearing parts such as distributor caps, rotors, contacts and capacitors.

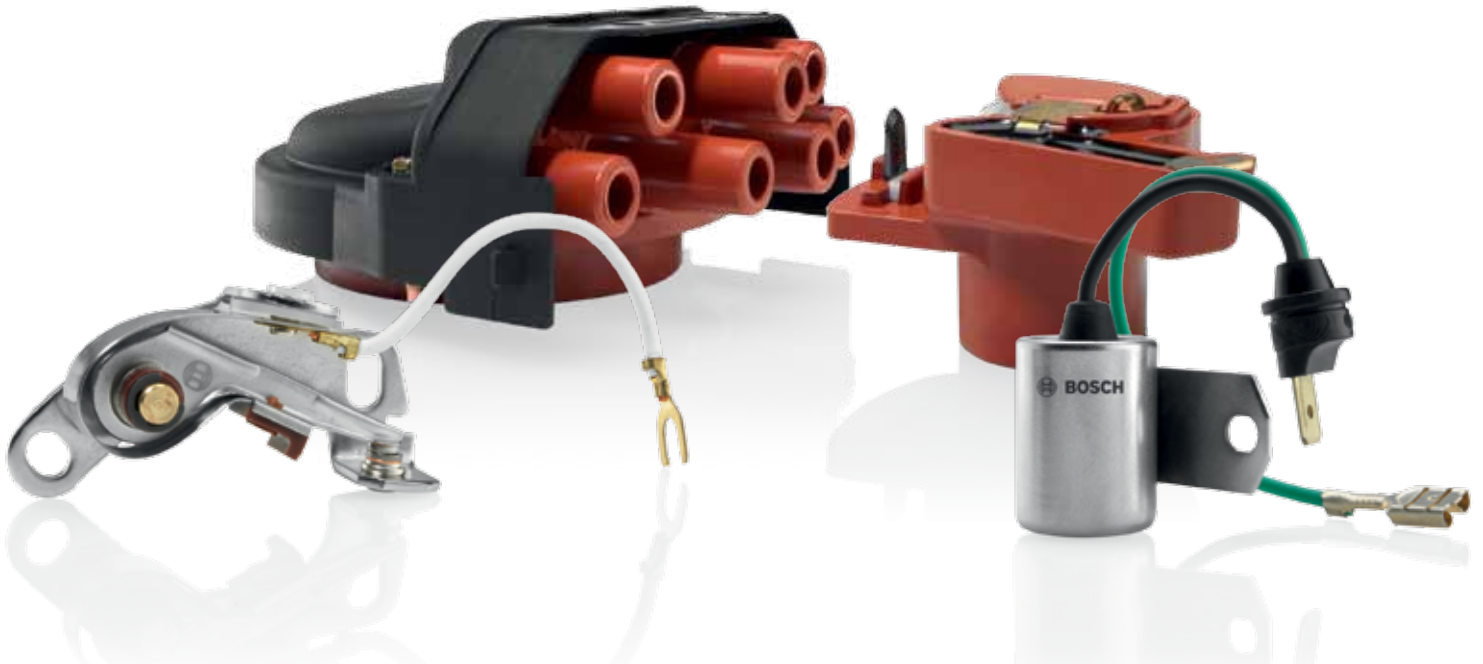

The ignition distributor distributes the high voltage (ignition sparks) to the engine's respective operating cylinder (ignition sequence).



There is high tension inside ignition distributor caps. The components can feature voltages of up to 30 000 volts. Inside the resilient housing, the sparks jump from the rotor to the ignition contacts.



Ignition distributor rotor: engine protection by speed limiting
Distributor rotors are made from the same material as distributor caps. There are distributor rotors with engine speed limiter and those without. The speed determined by the centrifugal force is limited by short-circuiting the ignition voltage.

Advantages at a glance:

- ▶ **Ignition distributor caps and rotors feature a particularly high resistance to chemical influences and tracking** since the spark discharge between rotor and ignition contacts generates a lot of heat and a large amount of aggressive nitrogen oxide.
- ▶ **In order to cope with constant high tension during operation,** many distributor caps and rotors are made of fiberglass-reinforced polyester with an additional special surface sealing.

Spare parts for ignition distributors

Product details



Ignition contacts – also known as breaker contacts – are subject to extreme strains. The current flowing through the coil is switched

on and off by a contact within the ignition distributor. These components feature a particularly high quality – after all, they often have to cope with more than 100 million switching cycles.



Ignition capacitors prevent early loss of ignition-contact materials as they store the charge and the respective energy statically in electric fields within DC circuits. Workshops thus rely

on Bosch ignition capacitors – for their high quality.

Advantages at a glance:

- ▶ **The contact surfaces of the ignition contacts are subject to particularly high strains.** That's why they are made out of nickel. This material doesn't wear off physically, it is temperature-resistant and yet it features top electrical properties.
- ▶ **Breaker-switched ignition systems** without ignition capacitor are very limited concerning their operation. Therefore, they are equipped with Bosch ignition capacitors of particularly high quality.



Troubleshooting and repair

- ▶ **Quick and easy troubleshooting and repair** using Bosch test equipment and ESI[tronic] 2.0 workshop software
- ▶ **The Diagnostic Control Unit (DCU 220)** is designed for easy switching between tablet and notebook operation.
- ▶ **Its integrated camera** can be used to document irregularities on the vehicle or to take a picture of the spare parts required.

Bosch ignition modules

Product details

Bosch ignition modules you can trust: Bosch ignition modules are perfectly geared to the respective ignition system providing consistently high ignition voltages. Thanks to their reliability, they are often chosen as original equipment.



Bosch ignition modules reliably provide consistently high ignition voltage. Therefore, they are among the “key players” underneath the hood.

Advantages at a glance:

► **Thanks to their heat capacity, resistance and conductivity,** Bosch ignition modules feature a particularly high functional reliability.

- **Their absolute tightness** protects them against corrosion.
- **Simple installation:** Practical assembly materials are included within the scope of delivery.

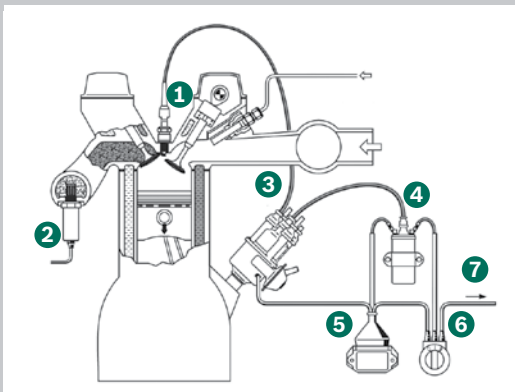

Bosch: systematic ignition

System with contact-free transistor ignition (TI):

- 1 Spark plugs
- 2 Lambda sensor
- 3 Ignition distributor with centrifugal-force mechanism, vacuum time management and inductance impulse generator or Hall generator (alternatively)
- 4 Ignition coil
- 5 Ignition module
- 6 Ignition switch
- 7 To the power supply (battery)

Bosch spark plugs

Product details

Bringing motorsport technology onto the road: Around the world, motorsport teams rely on Bosch spark plugs. Bosch launches racing innovations and experiences for workshops as well. Workshops customers can thus also benefit from the high performance, accuracy and quality of Bosch spark plugs.



Advantages at a glance:

- ▶ **The matching spark plug** with high quality and for almost any engine
- ▶ **Equipped with innovative technologies** used for original equipment
- ▶ Developed for particularly **high performance specifications**



Best Brand 2018 readers' poll



"auto motor und sport", issue 07/2018

Bosch spark plugs were voted "Best Brand"

For the 13th time already, the readers of "auto motor und sport" (a famous German motor magazine) chose the best brands in the areas of automotive accessories, suppliers and services at the renowned "BEST CARS" readers' poll (issue 07/2018).

Besides Bosch batteries, filters, wiper blades, workshop chains and tools, Bosch spark plugs were also voted "best brand".

Driven by efficiency

Bosch technologies are used worldwide in almost all vehicles. People, and assuring their mobility, is what we are focused on.

Therefore, we have dedicated the last 125 years of pioneering spirit and expertise in research and manufacturing to achieving this.

We continue to work on our unique combination of solutions for spare parts, diagnostic devices, workshop equipment and services:

- ▶ Solutions for efficient vehicle repairs
- ▶ Innovative workshop equipment and software
- ▶ The world's most comprehensive range of new and replacement parts
- ▶ Large network of wholesale customers, for quick and reliable parts supply
- ▶ Competent hotline support
- ▶ Comprehensive educational and training offers
- ▶ Targeted sales and marketing support

Additional information on Bosch ignition components upon request:

bosch-automotive-aftermarket.com

**What drives you,
drives us**

Robert Bosch GmbH
Automotive Aftermarket

Auf der Breit 4
76227 Karlsruhe
Germany

www.bosch-automotive-aftermarket.com



BOSCH
Invented for life

